

Legacy Car Plans

A comprehensive guide to help you build an official
Soap Box Derby® Legacy Division Car

Rev A - Updated January 2020 - Major additions highlighted in red

Table of Contents

Section 1: Introduction.....	Page 3
Section 2: Rules & Regulations.....	Page 4
Section 3: Car Dimensional Rules.....	Page 5
Section 4: Floorboard.....	Page 10
Section 5: Body Design.....	Page 12
Section 6: Body Construction.....	Page 16
Section 7: Axle Mounts.....	Page 19
Section 8: Steering and Brake Assembly.....	Page 22
Section 9: Airfoils and Body Fillets.....	Page 23
Section 10: Weights.....	Page 24
Section 11: Wheels.....	Page 25
Section 12: Building References.....	Page 25
Closing: A Word from your Legacy Committee.....	Page 26
Appendix A: Summary of Key Dimensions and Rules.....	Page 27
Appendix B: Axle Mount Stack-Up Reference Drawings.....	Page 28
Appendix C: Revision Log.....	Page 30

Section 1: Introduction

Welcome to Soap Box Derby® racing! The Soap Box Derby program is designed to be an enjoyable learning experience for both the adult and the child. The program provides an opportunity to develop mutual respect and trust while demonstrating the importance of individual pride and sportsmanship.

The Legacy Division is envisioned as the premier form of gravity racing in terms of both the design/build experience and the racing format. It is intended primarily for more experienced participants who have previously built and driven cars in one or more of the International Soap Box Derby (ISBD) Stock, Super Stock, or Masters Divisions. Participants in the Legacy Division must be twelve (12) years old by July 31 in the race year that they participate. They must not turn twenty-one (21) years of age on or before July 31. Proof of age is required.

Both the increased maximum weight (275 lbs. combined car and driver) and the generous minimum body dimensions for foot area, shoulder area, and overall length (detailed in Section 3) were carefully specified after considerable study to provide a path for older more experienced drivers to remain with the sport of Soap Box Derby® and race competitively well into their later teen years.

The rules in this Division are intended to allow for car designs that can be driven in either the Lay Back or Lean Forward positions. There will be minor rule differences regarding hatches, headrests, and foam for these two Legacy car types, as explained later sections. The two car types will otherwise compete together on equal terms.

In harmony with the Soap Box Derby® mission to promote Science, Technology, Engineering, and Math (STEM), the Legacy Division rules have been designed to allow for and encourage an increased level of design latitude versus the other ISBD Divisions. Details will follow in subsequent sections, and these areas include body and airfoil design and construction, modification to axle mounts or steering/brake assemblies, and variances in overall wheelbase. That said, the intent of the Legacy rule set is to ensure the construction of a top-class competitive car remains affordable, and the technology employed does not preclude construction in the average home shop or garage setting. More will be said on this in the appropriate sections.

Section 2: Rules and Regulations

The written rules, plans, and regulations are designed for the participant to construct the car from a Legacy Car kit purchased from the International Soap Box Derby, Inc. with the addition of certain materials provided by the builder. For rules and regulations, see the “Rule Book” available from the International Soap Box Derby, Inc. at soapboxderby.org. The established rules, plans, and regulations shall be applicable to all races and events and shall be taken into account as to all issues involving the construction of a car. By participating in these events, all participants are deemed to have consented to the rules and authority of the person who shall enforce the rules.

No expressed or implied warranties of any kind, including any warranty of safety, shall result from the publication or compliance with these rules, plans, and regulations. In no event shall the International Soap Box Derby, Inc. be liable for any loss, indirect, special, or consequential damages even if the International Soap Box Derby, Inc. has notice of possibility of such damages. The International Soap Box Derby, Inc. makes no warranties, including any warranties of fitness for particular purpose with respect to the publication or compliance with these rules, plans, or regulations. In all situations, the rules and regulations promulgated by the International Soap Box Derby, Inc. shall govern and control over any conflicting provision in these plans.

Each participant understands and agrees that a prerequisite to competing in any championship race sanctioned by the International Soap Box Derby Inc. in Akron, Ohio, that the racer and his or her car shall undergo and pass inspection conducted at Akron, Ohio by the International Soap Box Derby Inc. Each participant further understands and agrees that such inspection shall be conducted using the manner and methods deemed appropriate by the International Soap Box Derby Inc. in its sole discretion to determine compliance with the rules, plans, regulations, spirit of the rules and specifications applicable to that division and that the decisions of the International Soap Box Derby Inc. and its officials regarding qualifications and disqualification in compliance with the rules, spirit, plans, regulations and specifications applicable to that division shall be final and binding upon all parties.

This guide contains proprietary information of the International Soap Box Derby (ISBD). It is intended solely for the information and use of parties building a Soap Box Derby® Legacy Car. Such proprietary information may not be used, reproduced, or disclosed to any other parties for any other purpose without the expressed written permission of ISBD.

Section 3: Car Dimensional Rules

The dimensional rules of the Legacy Division are carefully designed to ensure drivers of a wide variety of physical sizes are able to compete on equal terms. Specifically, the foot and shoulder areas and overall length are larger than in other car classes to accommodate older drivers. A single common set of body geometry rules will be used to define both the Lean Forward and Lay Back car types.

The basic approach to establish limitations on body geometry is accomplished by taking width and height measurements at two Body Control Locations, one 10” back from the nose (the foot area), and the other 63” back from the nose (the shoulder area) per Figure 1. When the body cross sections are viewed looking fore-aft at either of these Control Locations, concave sections are not allowed (see Figure 2). This means that for a Lay Back car, the headrest will likely need to start aft of the rear Control Location. For a Lean Forward car, if a rear-hinged headrest (see Section 5) extends back through the rear Control Location, the geometry must be blended with the main body in such a way as to avoid creating concave sections.

At the front Control Location, 10” from the nose, overall height and width are measured, per Figure 1. The width is taken at a level 2” above the top of the front axle top surface, to clear any axle fillets that may be present and is sized to ensure a sufficiently wide area to place the driver’s feet.

To clarify, the front control location will always be taken at a location 10” back from the nose, regardless of axle position. While the axle (kingpin C/L) may be located anywhere from 7” to 13” from the nose, the minimum body width will always be measured 10” from the nose, at a level on the body 2” above the level of the front axle top surface, regardless of where the axle is located. This was done, so inspectors would not be faced with trying to measure width at a location where an airfoil/body fillet may interfere.

At the rear Control Location, 63” from the nose, overall height and width at 2” and 8” above the floorboard bottom surface are measured, per Figure 1. The two width measurements in the rear, ensure adequate space for broad-shouldered drivers. At no point shall any portion of the body be wider than the axle square stock.

Section 3: Car Dimensional Rules (cont.)

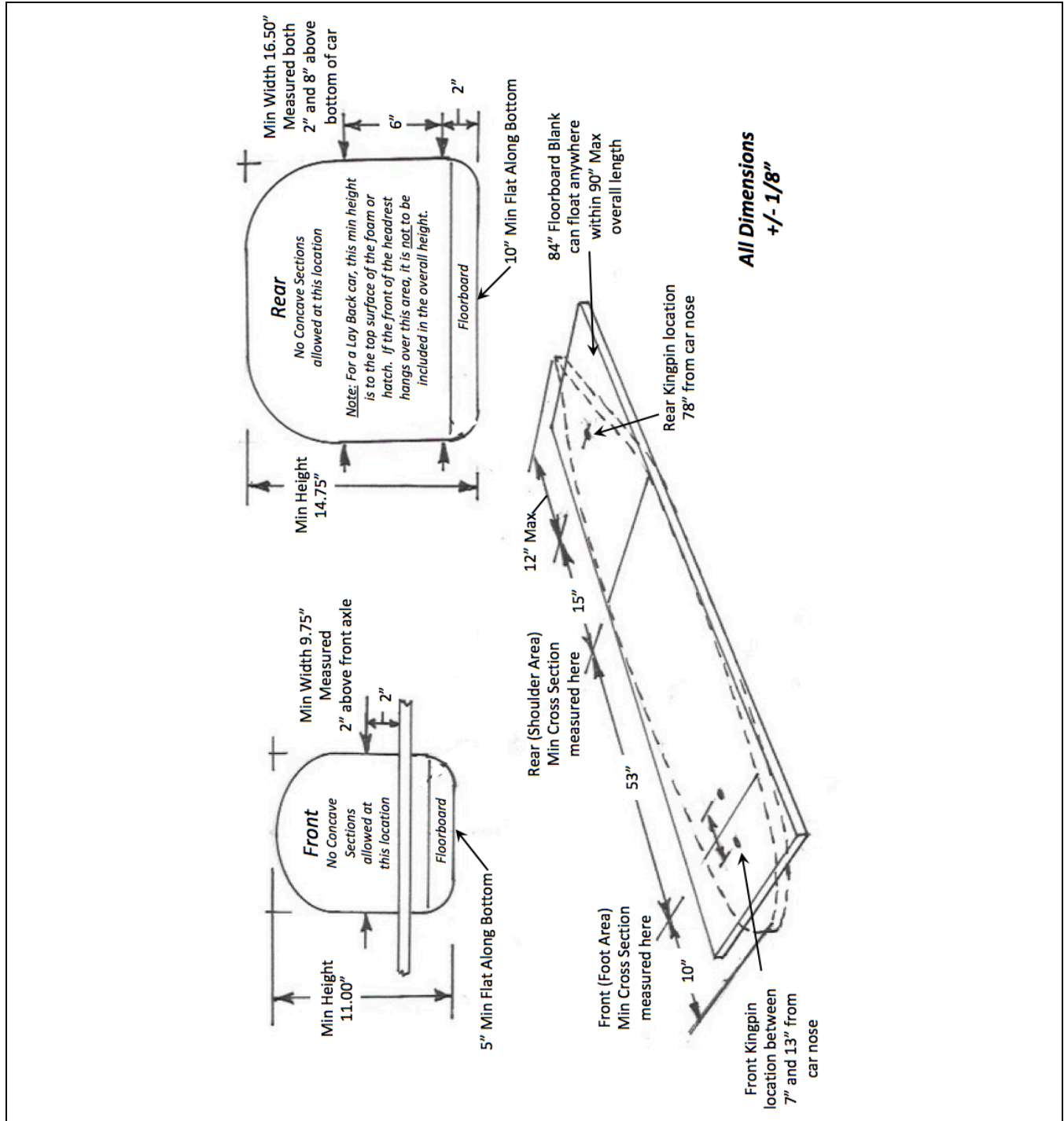

Figure 1 – Body Dimensional Rules

Section 3: Car Dimensional Rules (cont.)

Dimensional Tolerances

All measurements with regard to the body and floorboard dimensions, minimum ground clearance, and kingpin locations as outlined in this section and Figure 1 are plus or minus 1/8". This also applies to the hatch opening described in Section 5. Please note this tolerance is an absolute limit, meant to account for honest building errors, dimensional changes due to humidity, finish buildup, or other unforeseen factors. While it is the builder's prerogative to use these tolerances, in prior builders classes dimensional allowances were misunderstood or abused, creating issues. Please take this under advisement and build your car carefully, measuring each of the key dimensions multiple times as you go to ensure you remain well within the rule limitations. If prior to a race, your car is measured and found to be out of the dimensional limits you will be asked to correct the error prior to being allowed to race. Note, there is no tolerance allowed with regard to the requirement for concave surfaces at the two body control locations (see next section).

Allowable body cross-section geometry at Body Control Locations

At the two Body Control Locations (10" and 63" from the nose respectively) the cross section when viewed looking fore-aft shall be flat or convex at any point around the body circumference. In other words, no concave surfaces are allowed at these two locations. The only exception to this will be for axle fillets at the axle/body intersection, which may run through the front Control Location (more on axle fillets in Section 9). If needed, this requirement will be checked by placing a straight edge against any section of the circumference that appears to be concave. If a thin 0.010" feeler gauge can be passed between the straight edge and the surface of the body or floorboard, the surface there shall be deemed concave and will need to be filled or otherwise addressed prior to racing. Note, concave surfaces are allowed ahead of, in between, or aft of the two Body Control Locations, but at these two locations the body cross sections must be entirely flat or convex. See Figure 2 for examples.

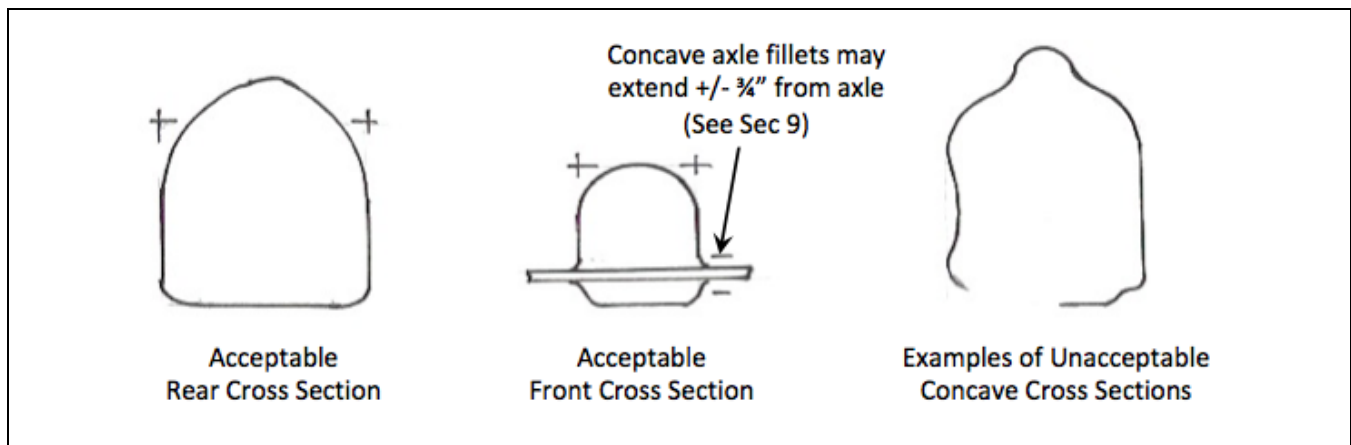

Figure 2 – Acceptable Cross Sections @ Body Control Locations

Section 3: Car Dimensional Rules (cont.)

Minimum Flat Area on Underside of Car

The bottom of the floorboard must remain flat over the minimum widths shown in Figure 1. In between these two locations, the floor must be also remain flat, tapering evenly from a 10” wide minimum flat section at the rear Control Location down to 5” wide minimum flat area at the Front Control Location. Forward, aft, and outboard of these locations, the floorboard is allowed to have curvature. This is done to ensure the cars sit securely on saw horses and trailers, making them easier and safer to handle.

Minimum Ground Clearance

Minimum ground clearance shall be nominally no less than 3” beneath the lowest point of the underside of the car including brake and brake facing. This will be checked by placing the driver in the car on a smooth flat surface, and a test block or gauge must then be able to pass beneath the lowest point and ground.

Section 3: Car Dimensional Rules (cont.)

Axle Requirements and Location

Only official ISBD-stamped axles dated 2004 or newer shall be used. No pre-bow (bending) of axles will be allowed, with measurements in the vertical and horizontal directions taken while the car is on stands (not under weight). Front axles shall be straight prior to application of steering cable tension. When cable tension is released, the front axle shall return to straight. Airfoils shall be removable for purposes of checking these requirements. Axles may be coated with either wax or oil to help avoid rust.

Axles must not be altered to change their geometry. Sanding, filing, grinding, peening, plating, pressing, rolling, coating, blueing, rusting, or similar processes are not allowable on either the square stock or spindles. The only exceptions to this are 1) the cleaning of rust from spindles or square stock using steel wool, scotch brite pads, or light sand paper; 2) the polishing of spindles using rubbing compound; and 3) the addition of additional steering cable and airfoil mounting holes, specifically and only as described below.

The drilling of one extra 3/16" maximum diameter hole on each side of the front axle within 1/2" inboard or outboard of the existing steering cable attachment hole (second hole from the outside). These two extra holes are allowed for purposes of looping the steering cable back upon itself, making for a more compact cable attachment easier to recess into a rear airfoil versus the traditional eye bolt (more on this in Section 8). If this system of cable attachment is used, these extra holes and the existing steering cable holes shall be lightly radiused, removing sharp edges to avoid cable fraying.

An allowance will be made for two new optional airfoil mounting holes drilled into each axle (front and rear) of 3/16" maximum diameter, located no more than 3" outboard of the existing inner airfoil holes, and centered on the axle thickness. The body fillet rules (Section 9) state the fillets cannot extend past the inner airfoil mounting holes. Fillets will be allowed to extend as far outward as the two optional new inner airfoil mounting holes. This change will provide builders additional space to fit their pins and accommodate a reasonable variety of body shapes and fillet styles.

The location of the rear axle is fixed, to ensure Legacy cars will fit on any ramp that accepts the current Masters Division cars. The centerline of the rear axle spindles shall be 78" from the nose of the car. The front axle location can vary as desired by the builder, but the centerline of the axle spindles must fall within 7" to 13" from the nose. It is acceptable to have multiple fixed mounting holes in the floorboard and mounting plates to allow the axle to be repositioned for different tracks (more detail in Section 7). It shall be noted specifically the +/- 1/8" tolerance applies to both these overall measurements (front axle absolute limits 6 7/8" to 13 1/8" from nose, rear axle absolute limit 77 7/8" to 78 1/8" from nose). As the Legacy cars will likely have body shells permanently affixed to the floorboard, the prescribed method for confirming these measurements will be to place the car on wheels nose into a flat surface like a wall, with the steering set straight. Measure back from this surface to each of the spindle centerlines to confirm the axle positions are within the allowable range. As the measurement of front axle location at the spindles will be taken while under cable tension, be sure to account for this when positioning the front kingpin hole

Section 4: Floorboard

The Legacy car kit provides a rectangular 84" long stamped ISBD floorboard blank. This floorboard comes undrilled, and the builder can use either the profile from the sample car plan provided, or design their own floorboard profile within the dimensional rules outlined here. The builder will also lay out and drill their own kingpin, mounting, and brake holes. After marking and carefully checking your dimensions, floorboards can be cut to shape using a saber saw, a hand saw, or a router and template. Similar to Masters, floorboards may be recessed up to $\frac{3}{4}$ " in depth under the driver's torso or foot areas as shown in Figure 3.

With the exception of rounding outside of the minimum flat area on the bottom and the optional recessed torso and foot areas, the remainder of the top and bottom of the floorboard must retain the as-provided surfaces, as shown in Figure 3. In other words, the bottom surfaces of the axle plates, weights, pulley assemblies, and steering/brake assembly must be mounted flat to the as-provided surface which is 1.5" above the as-provided bottom surface. Cars built in the 2019 season that do not comply with this will need to be modified by installing wood plates to raise this hardware to the original height.

Note, the floorboard blank provided is 84" long but the allowable overall car length is 90". It is expected that the nose area of the car will be made from either carved foam or wood covered in fiberglass (more on this in Section 6). As such, all or a portion of the missing 6" can be accommodated with the nose block. Any remaining length can be made up by fastening an extension to the tail of the floorboard, made from a section of the offcut ISBD floorboard or other non-metallic material. This extension can be bolted and/or glued on using a plywood splice plate and wood screws applied to the top surface. Tail or nose splice plates bonded to the top surface of the main floorboard shall not overlap it more than 1". The tail or nose pieces can also be fastened to the floorboard with wood dowels, splines, or biscuits if desired. **Noses must not be sharp.**

Details of the steel axle mounting plates will be covered in Section 7. Unless otherwise noted in this Plan, no additional plates, weights, or stiffening materials are allowed to be attached to or embedded in the top, bottom, or sides of the floorboard, beyond the fixed and adjustable weights outlined in Section 10, and the optional fiberglass exterior wrap outlined in Section 6. Any hole or flush fastener head on the bottom of the floorboard may be covered with removable tape. Floorboards may be coated with tung oil type finish.

Section 4: Floorboard (cont.)

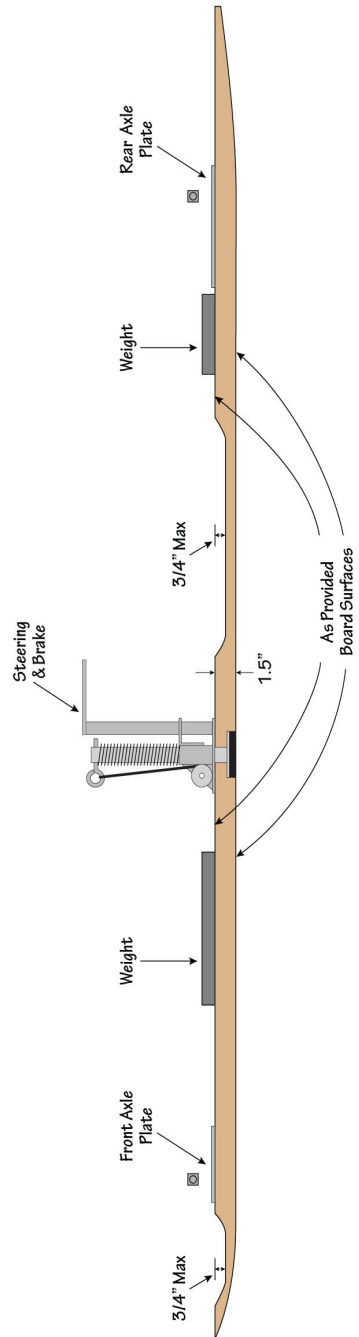

Figure 3 – Floorboard Thickness Clarifications

Section 5: Body Design

The Legacy Division offers two different body style options, the Lay Back car with a similar driving position to the current ISBD Masters Division and a Lean Forward car with a similar driving position to the Stock and Super Stock Divisions. Examples of each of these designs, conforming to the Legacy rule set are shown for reference in Figure 4. Drivers in both car types will use the official ISBD Masters-type plastic helmet.

A unique difference in the Legacy Lean Forward car option versus previous Lean Forward cars, is the optional use of a rear-hinged hatch to improve aerodynamics. This hatch can be made to be either flatter in shape, fitting around the back of the helmet, or a helmet fairing can be included similar to that on a Lay Back car which closes down over the back of the helmet. Note however, at the point the helmet fairing reaches the rear Body Control Location, it must be blended back into the body in such a way as to avoid creating a concave cross-section. The driver will still be required to enter the car with their helmet strapped in place on their head. More details will follow in the sub section on Hatch Design and Construction.

Section 5: Body Design (cont.)

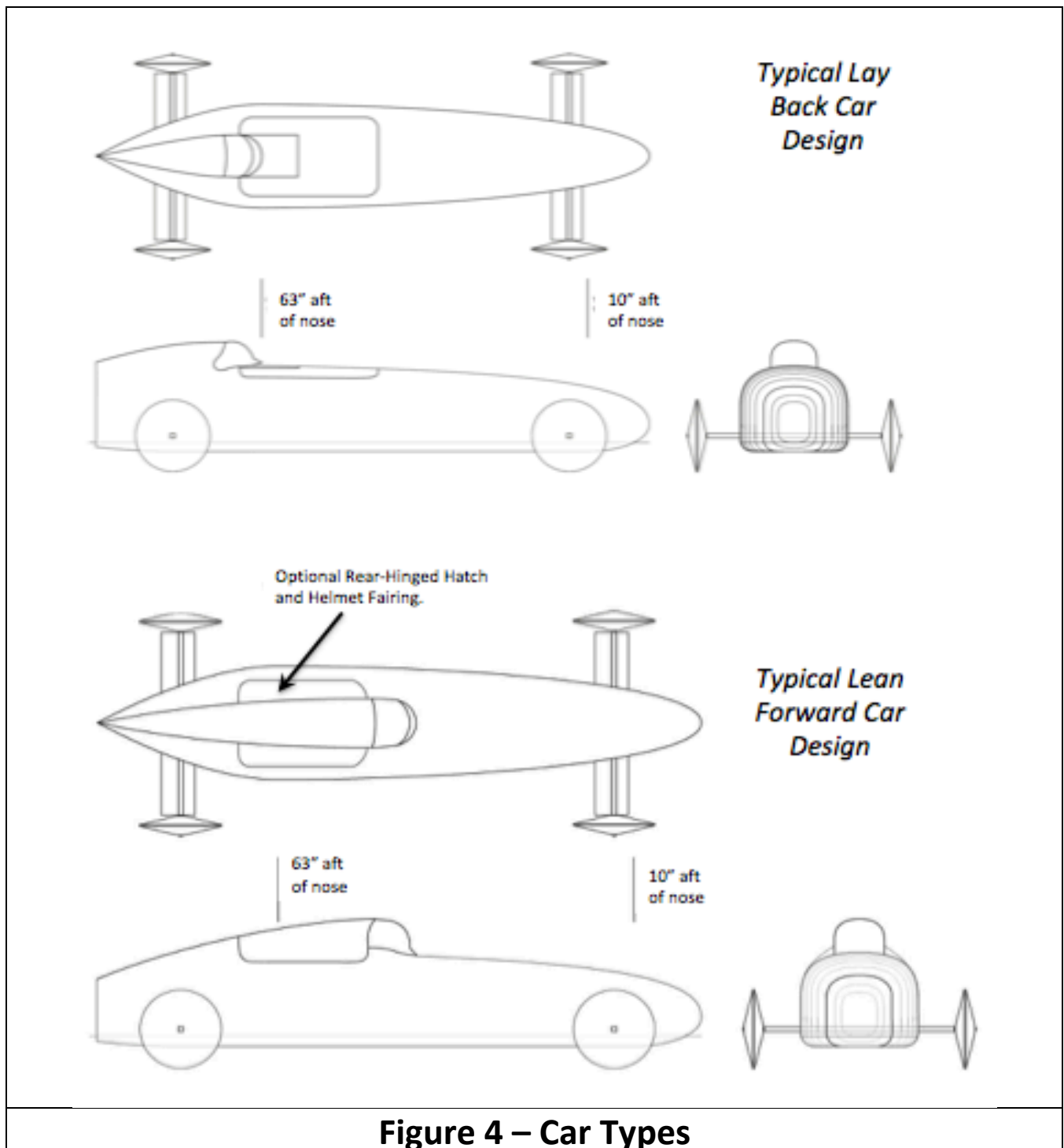

Section 5: Body Design (cont.)

Helmet Position and Sight Lines

- A direct line of sight over the body to the race course and tops of the front wheels is required at all times. No windshields, periscopes, mirrors, or other indirect sighting schemes will be permitted.
- The official helmet must not be recessed into the headrest as to restrict the driver's vision.
- The line of sight is defined as no part of the car, this includes the hatch foam on a Lay Back or forward foam on a Lean Forward, may be higher than the first rivet on the helmet, when the helmet is in race position. The first rivet must be visible at all times. See Figure 5.
- For the Lay Down car, ensure there is a minimum 7" wide opening from the cockpit hatch all the way back to the first rivet of the helmet. The only material allowed to intrude into this zone is to be ISBD White Masters Foam used to help support the helmet.
- For the Lean Forward car, the opening for the drivers face in the top of the shell shall be at least 7" in width, and lined with a minimum of one layer of 2" x 2" soft ISBD Stock Car Foam. This 7" minimum width shall be maintained back to 2" aft of the back of the helmet. The only material allowed to intrude into this zone is to be ISBD White Masters Foam used to help support the helmet. Pieces of this foam can also attached to the inside of the rear helmet fairing to help index the helmet location when the rear hatch is closed.
- For both car types, wood rails spaced at least 7" apart may be used to help provide a base for the helmet to sit on. These should be sanded smooth to avoid scraping the driver when entering the car. These rails may be extended inward of the 7" minimum opening using ISBD White Masters Foam.
- The helmet shall fit into the car and headrest in such a way to stay in position when the hatch is secure. It is permissible to use one strip of tape to help secure the helmet in position.

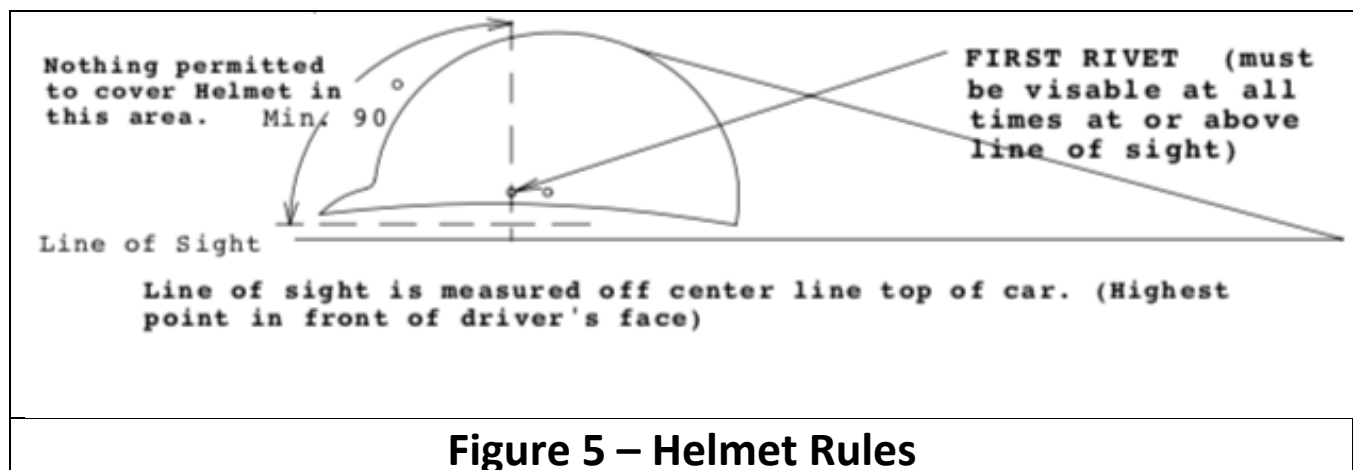

Section 5: Body Design (cont.)

Hatch Design and Construction

- Hatches on both the Lay Back and Lean Forward cars shall be constructed from similar materials to the main body and may in fact be cut from the body (see Section 6 for details).
- The minimum hatch opening in both car classes is 11” wide x 20” long as measured in a horizontal rectangle. It can be larger, and shall be large enough to allow the driver to easily get in or out of the car unassisted.
- On the Lay Back car, similar to an ISBD Masters hatch, 7” wide Dense White Sandable Masters Foam shall be installed to a minimum of 6” in front of the drivers face. No materials other than foam are allowed in this area. The foam shall not be painted, but may be dyed or colored with markers.
- On the Lean Forward car, the forward foam will be attached to the body in the front of the hatch opening, as described in the last section. If the optional rear-hinged hatch is designed to go around the back of the helmet, the area behind the helmet shall be padded with a minimum 7” width of 2” x 2” soft foam applied to the hatch. If the rear-hinged hatch is designed with a helmet fairing that folds down over the helmet, then pieces of either white or soft foam shall be applied to the inside of the fairing to help pad the helmet and index it into the correct driving position. It is recommended that one or more pieces of the Dense White Foam be cut to match the rear contour of the helmet and glued on edge to the inside of the fairing to help index the helmet when the hatch is closed.
- Either hatch type shall be hinged with the supplied ISBD single pin hinge or a single or double pin hinge of the builders choosing. Tape, nylon belting, metal chains, or cables are not suitable methods of hinging. Any hinges or attaching fasteners shall be mounted or cut flush and optionally covered with duct tape to ensure no sharp edges are present. Hinges shall not project into the driver compartment in a way that could present a hazard to the driver.
- A 2” x 2” clip will be allowed optionally on either inside edge of the hatch opening to prevent the body from spreading. This will be the only object allowed to protrude into the minimum hatch opening.
- The driver must be able to open and shut the hatch from inside the car. Velcro or magnets provided by the builder are two options for holding down the hatch. No latches are allowed that would prevent opening the hatch from either inside or outside the car.
- One strip of tape will be permitted at each corner of the hatch for added security against opening during the race, but this shall not be the primary means of securing the hatch closed.

Front Access Hatch

Unless the body shell is made to be removable, a forward access hatch is required to facilitate inspection or repairs. The opening shall be located on the top center of the forward shell, roughly over the front axle mount. It must be large enough to reach inside to make repairs or adjustments. The minimum size opening is 3” x 3”, and the builder shall provide a means other than tape to secure the hatch.

Section 6: Body Construction

Allowable Materials and Methods

The car body may be constructed from a variety of different methods and materials, some traditional and others quite modern. This approach was selected to allow builders to experiment with different methods, many of which teach important STEM fundamentals applicable to the automotive, aerospace, and fabrication industries. At the same time, certain construction limitations are outlined here to help control the cost and complexity of building a Legacy car, in keeping with the primary objective of enabling very competitive cars to be constructed by young adults working in the average home shop or garage. Note, while viewed by some as “old fashioned” the wood stick car covered in fiberglass can be highly competitive.

Recommended references to help quickly learn several applicable techniques follow in Section 12.

To control both cost and complexity, methods that entail the construction of a separate metal or fiberglass female mold from a body plug will not be allowed, with the exception of the nose piece or helmet fairing. Likewise, shells cannot be formed from sheet metal. Temporary exterior frames of wood or other material to support sticks or planks or wood, foam, etc. prior to glassing is an acceptable option.

It is assumed in most cases, the builder will choose to permanently attach the body shell to the floorboard, although this is not a requirement. In either case, it is suggested that the builder install nailer strips around the upper perimeter of the floorboard. Nailers provide additional flat area to affix the body once the main floorboard has been radiused. 1” x 1” is the maximum size for these nailer strips and they must clear any weights or hardware including axle mounting plates by at least 1/8”. Nailers are not allowed to bridge over weights or other hardware. Nailers must be constructed from wood, and hardwoods like oak or maple are good choices. These can be fastened to both the shell and floorboard with glue and screws providing a much more rigid connection. The glue can form a fillet up to 1/4” from the nailer.

Nailers are the only body elements other than the nose or tail splice plates (Section 4) that may be bonded or fastened to the upper surface of the floorboard. The body or body formers may be affixed to the top and outside surface of the nailers, or the edge of the floorboard itself, but these elements must not be bonded or attached directly to the upper surface of the floorboard.

If the body is removable, a minimum of 48 body screws shall be used, with one centered on the nose. These can be countersunk in the body and threaded into either the floorboard or nailers to form a very secure connection.

Section 6: Body Construction (cont.)

Suggested shell construction methods include, but are not limited to:

1) Traditional wooden stick construction over permanent or removable wooden frames or formers. Following sanding to final shape, the shell can be optionally covered with fiberglass or carbon fiber type fabrics using epoxy or polyester resin.

2) Fiberglass or carbon fiber type fabrics applied over a carved foam plug. Foam can be easily and quickly formed into complex shapes using sanding blocks and hand tools, with plywood or Masonite templates used to help guide the contour. Following glassing, the foam can either be fully removed by hand or using solvents or left partially in place and glassed from the inside to form a strong but light sandwich construction. Many high performance homebuilt aircraft and racecar bodies are built using this technique.

3) Foam planks laid over temporary male or female frames, then covered with fiberglass or carbon fiber. This technique is often used to build custom boats and creates a strong sandwich construction.

4) Modification of an existing Masters shell by splitting it down the middle to increase the width and raising it on nailers. The gaps will then need to be filled, the shell extended at the tail if desired using wood or fiberglass, and a hatch built to match the new opening. Method 4 is included here as an option, but may actually entail more work than methods 1 to 3.

Special Note: Any glass or carbon materials used inside the body shell, must not extend onto the upper surface of the floorboard. It is acceptable for these materials to cover the nailers.

Section 6: Body Construction (cont.)

Finishes

Bodies may be finished with auto body fillers (e.g. Bondo), primer, and other conventional auto body finishes. Vinyl wraps are another option. If modifying an existing Masters shell, it may be covered with additional layers of fiberglass or carbon fiber type fabrics or tape prior to painting. Vinyl decals may be over-coated with clear finish.

The AASBD sponsor logo is required to be applied on both sides of the forward half of the car body. It is acceptable to overcoat this decal with clear paint finish alone (not fiberglass cloth) so long as it is not obscured or discolored in any way. The drivers Region number must also appear on the car in 1.5" or larger lettering.

Special Note: All finishes on the flat area under the floorboard must remain transparent. The flat area is defined as the trapezoidal area formed by the 5" minimum flat width at the Front Body Control Location and the 10" minimum flat width at the Rear Body Control Location and the area in between (see Fig. 1). This means if carbon fiber type fabric or other opaque materials are used, they must not extend onto this portion. This area must not be painted or primed, but can be covered with clear finishes. Glass cloth will be considered a clear finish if put in place with a transparent resin. The reason for this is to help ensure the floorboard remains unaltered and contains no elements not allowed by the rules outlined here. Note other methods of inspection may also be employed to help ensure the floorboard is unaltered.

It should be noted that if elevator bolts, T-nuts, or washers are mounted in the underside of the flat area, it is acceptable to cover these with "Bondo" type fillers, and this filler need not be transparent. This filler should be confined to the are immediately over the fastener head. It should be obvious during inspection from above or below that the filler is covering a fastener used to affix and element of the car.

A cautionary note regarding finish buildup and tolerances: For any of the methods where fabric covering will be applied over a substrate, please take special care to ensure an allowance is made for the thickness of material you intend to apply when laying out your floorboard and body dimensions, kingpin locations, etc. In particular, take precaution to avoid issues with having your car end up over maximum length, below minimum ground clearance, or having the axles fall too far from the nose. In other words, when laying out the height of your axle mounts, the kingpin locations, and the body be sure subtract the anticipated thickness of the glass and any finishes you intend to later apply from these key dimensions.

Section 7: Axle Mounts

Axle Mounting Plates

The Legacy kit provides front and rear ISBD-stamped Masters steel mounting plates. These must be used in the conventional positions and orientation to form a solid base for both the front and rear axle mounts. It is optional to add additional ISBD Masters mounting plates on top of the provided plates. While it is not acceptable to fabricate custom axle mounting plates, the ISBD mounting plates may have the holes enlarged or additional holes drilled to accommodate custom axle mounts designed by the builder as described in subsequent sections. The mounting plates must remain unpainted and the stamped logo must remain visible once any hardware is in place.

The axle mounting plates may not be glued to the floorboard. The reason for this is to allow disassembly of the entire axle mount for examination of winning cars or at other times as needed. It is optional to use ISBD ¼” bushings in the floorboard as part of the axle mount or mounting plate attachments and these bushings may be glued into the floorboard.

The axle mounting plates may be attached to the floorboard with the provided ¼” Elevator bolts, lock washers, and nuts, or other mounting bolts provided by the builder. **Longer or shorter fasteners and/or non-AASBD washers up to 2” in outer diameter may also be used in axle mount construction.** There shall be no less than four mounting fasteners in each plate, and these fasteners must be a minimum of ¼” in diameter. Larger diameter fasteners are permissible. The use of T-nuts installed from under the floorboard is acceptable for mounting the plates or other axle mount components. Elevator bolts or T-nuts may be recessed and glued into the underside of the floorboard, and optionally covered with fiberglass, but again the mounting plates and all axle mounting hardware above the plates must remain fully removable for inspection. The use of threaded inserts in the floorboard as a method of attaching the plates is not acceptable.

Standard Axle Mount Options

The kit provides hardware to construct the standard ISBD Masters 2-Bolt (aka “Super Stock”) rear axle mount. The 3-Point Square Tube Masters rear axle mount may be purchased separately as another option. The kit also provides hardware to construct the standard ISBD Masters front axle mount and steering stops.

As with the Masters division, it is acceptable for the builder to install washer stacks of their choice front and rear, using the standard selection of unmodified ISBD washers, provided the minimum ground clearance is maintained. Any of these standard axle mounting options can be set up to be quite competitive and detailed assembly instructions are published in the Masters Car Plan available online.

Section 7: Axle Mounts (cont.)

Custom Axle Mount Options

In addition to the standard ISBD axle mount options, the Legacy Division allows for the design and construction of custom axle mounts (see Fig. 6 for an example) under the following restrictions:

- The axle mount must be secure and safe and hold the axle at a fixed elevation and wheelbase through the entirety of the race. Designs that allow the axle position to **mechanically** change during the race are not allowed. **Ordinary flexibility in metallic axle mount or plate components is acceptable and shall not constitute a gross change in axle elevation.**
- The front axle mount must include some form of axle stops. These shall limit steering movement of the front axle as measured at the spindle ends to no more than 1 5/8" or less than 3/8" off center (straight-ahead position) in either direction forward and back.
- Axle mounts shall be constructed from stock or modified ISBD axle mount hardware and fasteners. The only exception is longer or larger diameter bolts as required and purchased separately by the builder.
- The axle assembly is to be held together by threaded fasteners alone and must be able to be fully disassembled for inspection. No welding, brazing, soldering, or gluing of axle mount components will be allowed, the only exception being floor board bushings and elevator bolts, T-nuts, or washers on the bottom side of the floorboard which may be glued in place or covered with fiberglass.
- Bolt heads on the bottom of the car including both kingpins must remain accessible for tool removal, but if set in recessed holes these holes may be covered with removable tape.
- Axles must be supported by a 1/4-28 Grade 8 (Yellow) kingpin through the unmodified center hole in the axle. Kingpins in 3 1/4" and 3 1/2" length are available through the ISBD, and longer or shorter 1/4-28 Grade 8 kingpins are available through specialty fastener stores or numerous online sources.
- The kingpin must at a minimum pass through one properly affixed ISBD axle mounting plate, but need not necessarily pass through a bushing in the floorboard.
- Kingpins may not be glued in place, and must be fully removable without requiring the removal the axle plates or other axle mount hardware.
- Front kingpins must be held in place with at least two ISBD 1/4-28 Grade 8 lock nuts with the top nut including the nylon lock ring fully threaded onto the kingpin threads. Rear kingpins must be held in place with at least one ISBD lock nut, similarly engaged.
- Axle mount components may be constructed using cut pieces of ISBD 3/4" cold-rolled steel axle stock material. These pieces may be cut to length, and drilled, tapped, filed, ground, or sanded to produce shapes suitable for axle mounting. It is acceptable to reduce the thickness or width of the 3/4" stock if needed and to create radiuses or other profiles as needed. This work must be carried out by the builder.
- Any piece of axle material that comes into direct bearing contact with the axle top, bottom, or side must have an ISBD stamp visible **or visible upon disassembly**. Sections of ISBD axle used to construct or support non-bearing sections of the axle mount, not come in direct contract with the axle, need not necessarily include a stamped section of the axle stock from which they were made.
- The use of thin metal shim stock is acceptable within the axle mount assembly for alignment purposes.

Section 7: Axle Mounts (cont.)

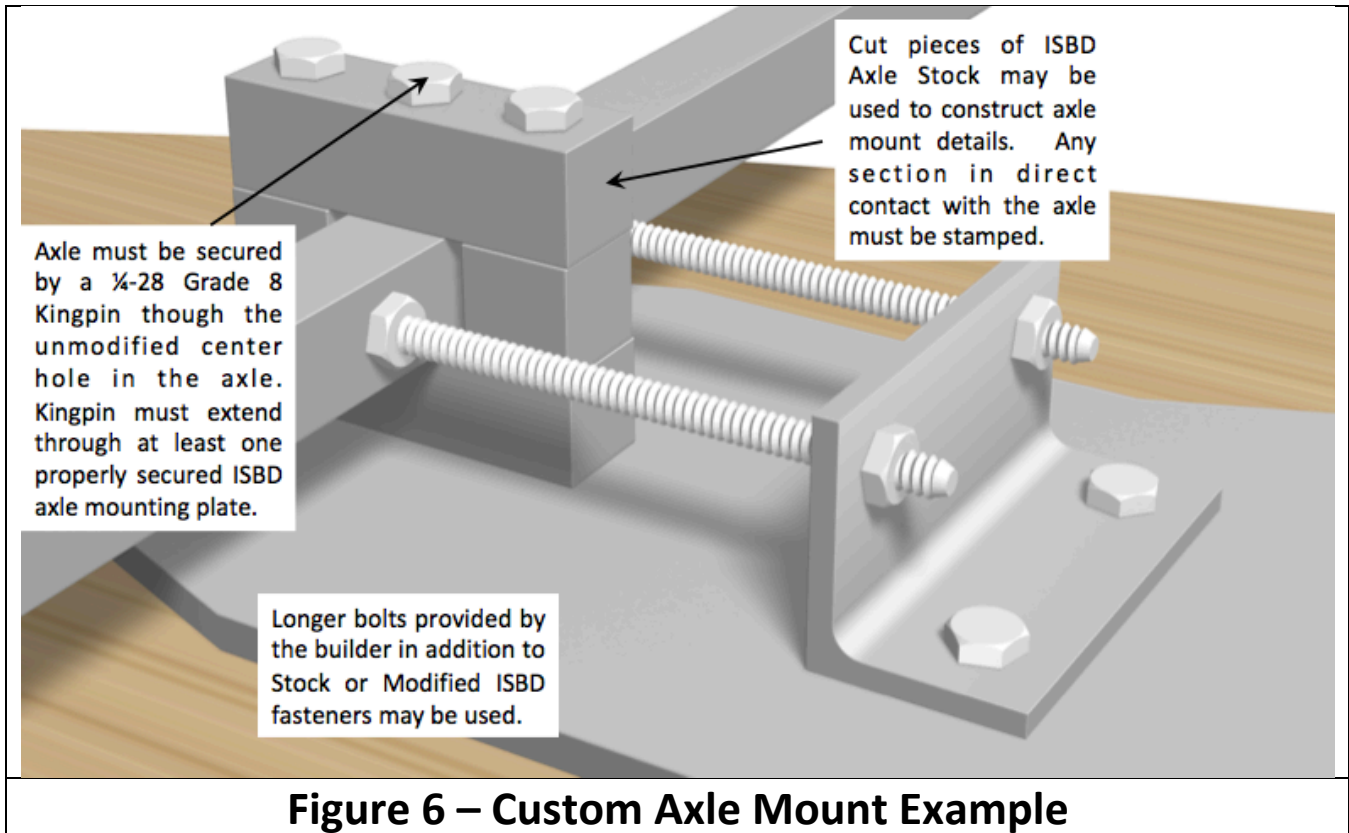

Variable Wheel Base Front Axle Mounts

As outlined in Section 3, the distance from the nose to front axle centerline (measured at the spindles) can be selected by the builder, within the specified range. It is acceptable to design a system of front kingpin holes, axle mount and mounting plate holes, and axle body clearance holes, that allow the front axle to be repositioned in between races to adopt to different track or ramp configurations. For example, some tracks may favor a longer wheelbase, while others may favor a shorter one.

Adjustable front axle mounts shall be designed to remain in a single fixed position during the entirety of the race. In other words, once the axle position is fixed and any attaching fasteners are tightened down, it shall remain fixed (with the exception of normal steering movement). Changes to the wheel base are to be made only at the specified times race officials allow adjustments to be made to the cars.

Section 8: Steering and Brake Assembly

Available Steering and Brake Options

The Legacy kit provides either the basic ISBD Masters Steering & Brake Assembly (for use with a separate brake pedal) or the ISBD Masters Hand Brake Assembly. The builder must select one of these two basic options for the steering of their car. The Steering & Brake Assembly shall be fastened in place using ¼” elevator bolts, washers, lock washers, and nuts or ¼” bolts and T-nuts installed from below. Instructions for setting up these steering/brake assemblies can be found in the Masters Car Plan. Similar to the Masters Division, brake stems and pads may be countersunk flush into the floorboard.

If the standard Steering & Brake Assembly is selected, either a standard plywood brake pedal or a “trapeze” type brake pedal provided by the builder may be used. Designs similar to those that have been deemed acceptable for use in the Masters Division will be suitable. Independent of the brake pedal design selected, all brakes must be designed with appropriate return springs, stops, cable retainers, etc. to ensure the brake does not bind or become detached during operation. Double cable clamps are required on all cable connections and it is recommended that these be double looped as well.

Allowable Modifications

The builder is allowed to make minor modifications the standard Steering & Brake Assembly to increase precision or adjustability. This includes sanding or polishing surfaces, careful and slight bending of the basic components, or the addition of standard hardware store items like collars and fasteners. Additionally, holes may be drilled or tapped to add adjustable features. Examples of this type of modification include the addition of a thrust bearing under the steering column or the addition of collars to the steering column to remove play in the mechanism. No welding is allowed. The builder must exercise care and thought to ensure there is no chance of binding or restricted movement in either the steering or brake. **It is allowable to re-paint the steering assembly so long as the original OSHA “Safety Blue” (aka Royal Blue) color is used.**

Steering Cable Routing

Steering cable routing is left up to the builder with the following restrictions:

- Each side of the cable must make a full wrap of the steering column (similar to other Divisions).
- The cable must be routed around a pulley on each side of the car immediately prior to exiting the body, and the center of each of these pulleys shall be no less than 22” from the back surface of the front axle. Cables may not cross each other between these pulleys and the front axle.
- Cables must be attached at both ends of the front axle through the standard steering cable hole. An optional extra hole is allowed near each steering cable hole to allow the cable to be looped back to fit more easily in rear airfoils (see Section 3, Axles). Double cable clamps are required at the point of attachment to the axle.
- A means of cable length adjustment is required. Ring-type adjustors are a suggested option.

Section 9: Airfoils and Body Fillets

Airfoils

The Legacy Division allows for the use of airfoils on both the leading and trailing edges of both axles. The design, material selection, and finish of these airfoils will be left up to the builder with the following restrictions:

- Airfoils on the leading edge of each axle shall be no more than 2” in width. Airfoils on the trailing edge of each axle shall be no more than 3” in width.
- The leading edge airfoils on either axle shall not be sharp in profile.
- Airfoils shall not protrude beyond the end of the axle square stock (no tolerance applicable here).
- Leading edge airfoils must be screwed, bolted, or pinned to the axle using the two predrilled holes in the axle. The trailing edge may be fastened with screws, pins, bolts, magnets, or a combination thereof. A common attachment method is pins through the axle into the airfoils with tape around the airfoils.
- Tape alone to secure the airfoil will not be allowed.
- The material and finish of the airfoils should be robust to avoid damage during car handling.
- The gap between the body and the airfoil or the airfoil and the body fillet may be filled with foam. This foam must be installed on the end of the airfoil and conform to the same profile as the airfoil.
- Airfoils must in no way cover the top or bottom surfaces of the axle (excepting body fillets).
- Airfoils shall be easily removable to allow inspection of the steering cable attachment.

Body Fillets

Fillets are surfaces that form a radius to improve aerodynamics at the junction between the axle and the body by reducing interference drag. These can be constructed from materials including but not limited to body filler, moldable silicone rubber, sheet rubber, sections of wood airfoil stock, etc. and can be painted to match the body. Fillets may be used, with the following restrictions:

- Must be securely attached to the body and not prevent removal of the airfoils.
- May in no way interfere with normal steering movement of the front axle.
- May cross the axle top and bottom but must not be bonded to these surfaces.
- May extend up to 1” in front of or behind the leading or trailing edges of the airfoil.
- May extend up to ¾” above or below the top or bottom surfaces of the axle.
- May not extend past the location of the inner airfoil mounting axle hole (both holes on each side must be used to attach the airfoils to the axle).

Section 10: Weights

Note: All weights must be painted and the weight of each piece clearly marked

Fixed Weight

- Combined weight of the car and driver with Z-Glas wheels shall not be greater than 275 pounds, **or less than 273 pounds.**
- The maximum length for weight plates shall not exceed 12”.
- The maximum combined height of weight plates or bars shall not exceed 1 ½”.
- The weights must be removable without removing any running gear, steering, or brake components.
- When unbolted from the car (sitting free) weights shall be flat.
- At least (1) but no more than (2) 5/16” bolts per plate are required to secure weight.
- A 1/8” gap must be maintained between weights.
- T-Nuts may be used to secure weights if installed from below. T-Nuts may be glued in place or covered with fiberglass, but the weight bolts must be free to be removed.

Adjustable Weight

- Each car must have at least one anchoring bolt or threaded rod with a wing nut safely installed in the car body for quick adjustment of weight.
- The recommended amount of adjustable weight is ten pounds.
- If bar bell style weights are used, the large center hole must be filled with a drilled dowel rod allowing the weights to fit securely on the 5/16” weight bolt.
- Adjustable weight stacks between the driver’s legs and the steering shaft shall not exceed 1 ½” in height.
- In a Lay Down car, if there is an adjustable weight stack under the drivers head area, any excess length must be cut off the bolt and the stack must be padded.
- Stack all adjustable weights from largest (footprint) on the bottom to smallest on top.

Prohibited Weight

- Weights are not allowed to bridge over one another or other hardware or cables.
- Shifting or any type of movement in the weights is prohibited
- Weights may not touch sides of the car or any assemblies.
- Pouring of melted metal into the car floorboard or body is prohibited. All weight must be removable.
- Welding of weights together is not permitted.
- Wing nuts are not permitted on weights under the driver’s body.
- Weight is not permitted in a seating or heel area that has been recessed.
- Weights which overlap to create more than 12” support to the floorboard are not allowed.
- No cushion (sponge rubber, springs, etc) may be used between the weight and floorboard.
- Threaded inserts in the floorboard are not allowed to secure weights.

Section 11: Wheels

Four wheels must be run on the car: two front and two rear. ALL FOUR WHEELS MUST TOUCH THE GROUND AT ALL TIMES.

Only official unaltered Soap Box Derby wheels can be used.

Tampering with or altering in any way, any part of the wheels, bearings, or tires is prohibited and may be cause for disqualification.

Section 12: Building References

There are numerous references available online that will quickly help prospective builders learn the basic skills needed to construct a Legacy car. Suggestions include:

- 1) **Senior Construction Manual, author David Seitzinger;** Available at no charge, Google the title and author name to download a PDF copy. This book does an outstanding job describing several methods for designing and building a stick car. It also includes useful info on axle mount design. Note, the specific dimensions and some of the construction details are not applicable to the Legacy rule set, but the basic construction techniques are highly relevant.
- 2) **Winning Ingredients for Soap Box Derby Racers, author David Fulton;** Available directly from the author at www.winningingredients.com or through other online retailers. Note the original version of this book (vs. the newer Kit Car edition) is more relevant to the Legacy cars. Includes outstanding material on the design of cars and axle mount systems. Again, some of the specific design details are not applicable to Legacy, but the fundamentals certainly are.
- 3) **YouTube:** There are literally hundreds of videos available online to help take the mystery out of the types of construction and materials you will use to construct your Legacy car. For starting points on composite construction, search under **“fiberglass over foam”** or **“foam core boat building”**. As a starting point for stick construction search for **“fiberglass stick canoe”**.
- 4) **Legacy Sample Car Design:** David Seitzinger was kind enough to design a prototype Lay Back car to our Legacy car rules. The plans include dimensioned templates for the floorboard and body formers that can be printed full-size at a blueprint shop. This design provides a good starting point use as is or modify into other similar configurations. A PDF of the drawings is available by emailing the Legacy Committee (contact info at the end of this document) or as a download from the Legacy Division page on the AASBD website.

In Closing

If you have questions about the rules outlined here or the design and building of your Legacy car, we would like to help. Please address **email inquiries to:** soapbox@soapboxderby.org **Attn: Legacy Committee** and we will try to answer quickly. As new questions come in, a FAQ will be maintained on the Legacy Division page of the AASBD website to share guidance.

Development of the Legacy Division occurred from 2017-18 thanks to the hard work of a dedicated group of volunteers, each of whom care deeply about the sport of Soap Box Derby. The vision was a car design that allows experienced drivers to stay with the sport longer, a set of construction rules that promotes individual creativity and STEM principles in car design, and finally a race format that clearly identifies the finest teams each year in this very competitive Division. In short, *the Grand Prix of Gravity Racing!*

While no rule set will ever be perfect or appeal to every single individual, we hope we've done a good job balancing these objectives. As details of the proposal were made public, we collected literally hundreds of comments via social media, email, and comment cards. We considered this feedback very carefully. Hundreds of man-hours went into researching and debating the merits of various proposals or ideas, trying to strike the right balance in each of the many areas. This was not always easy, but our Team worked very well together. It helped that we had several very talented builders involved as well as individuals who'd been leaders in rule making and inspection going back many decades.

Please keep in mind writing a new set of rules for a Division with this level of complexity presents unique challenges. We fully appreciate the disruption and frustration frequent rule changes can create and it is our goal that the Legacy Car Rules remain as stable as possible. That said, the need to address unforeseen issues and/or keep the different car types at parity may necessitate adjustment as time goes on. We will seek to minimize this, but thank you in advance for your patience and understanding.

In closing, we hope you are pleased with the results of this effort. It is our sincere wish that building and racing a Legacy car will represent the pinnacle of your Soap Box Derby® experience, bringing with it great pride and joy in the process. Thank you and we look forward to hearing from you, helping out where we can, and seeing the fine cars you bring forth competing for glory on Derby Downs.

Respectfully your ISBD Legacy Committee ~

Core Members: Bob Cooper, Rich Johnson, Bobby Nickoli, Jim Hagan, Al Garren, Don Huminsky, Will Looman, and David Seitzinger. With special assistance from: Mark Gerberich, Mark Mroczynski, Larry Gallimore, Mark Packard, Marty Sullivan, and Paul Gale

Appendix 1: Rules Summary

Legacy Division Key Dimensions and Requirements			
Section	Description	Nominal Requirement**	Page
Section 3 Car Dimensions	Front body dimension Control Location (see Figure 1 for detail)	10" from Nose	6
	Rear body dimension Control Location (see Figure 1 for detail)	63" from Nose	6
	Front kingpin location (See Figure 1)	7" to 13" from Nose	6 & 9
	Rear kingpin location (See Figure 1)	78" from Nose	6 & 9
	Maximum overall car length nose to tail	90"	6
	Minimum flat area on underside of car (See Figure 1 for detail)	5"Front, 53" Long, 10" Rear	8
	Minimum ground clearance (w/ driver at final weight)	3"	8
Section 4 Floorboard	Maximum floorboard recessing under driver torso and feet	3/4"	10
	Maximum overlap of nose or tail splices onto floorboard	1"	10
Sections 5 & 6 Body Design and Construction	Minimum main hatch opening	11" x 20"	15
	Mimimum open width forward of driver's face	7"	14 & 15
	Minimum front access hatch opening	3" x 3"	15
	Maximum nailer cross-section	1" x 1"	16
Sections 7 & 8 Axle Mounts and Steering	Maximum washer diameter for axle mounting, etc.	2"	19
	Axle mount kinpin type	1/4-28 Grade 8 (Yellow)	20
	Steering pulley minimum distance C/L to Rear Surface of Front Axle	22"	22
Section 9 Airfoils and Body Fillets	Leading edge airfoil maximum width	2"	23
	Trailing edge airfoil maximum width	3"	23
	Body fillet max extension forward or back of airfoil	1"	23
	Body fillet max extension above or below axle	3/4"	23
Section11 Weights	Minimum weight w/ driver and Z-Glas wheels	273 lbs	25
	Maximum weight w/ driver and Z-Glas wheels	275 lbs	25
** A tolerance not to exceed +/- 1/8" may be applied to the nominal dimensions noted here. See pages 7 & 18 for restrictions.			

Appendix 2: Axle Mount Stack Ups

Axle Mount Stack Up – Legacy

The sketch below shows the dimensions for an axle mount stack up using a Z-Glas wheel with minimum ground clearance.

A Legacy floorboard sold by Akron can be bowed front to back which will impact ground clearance. During the build process, a floorboard can be intentionally or unintentionally bowed which will impact ground clearance.

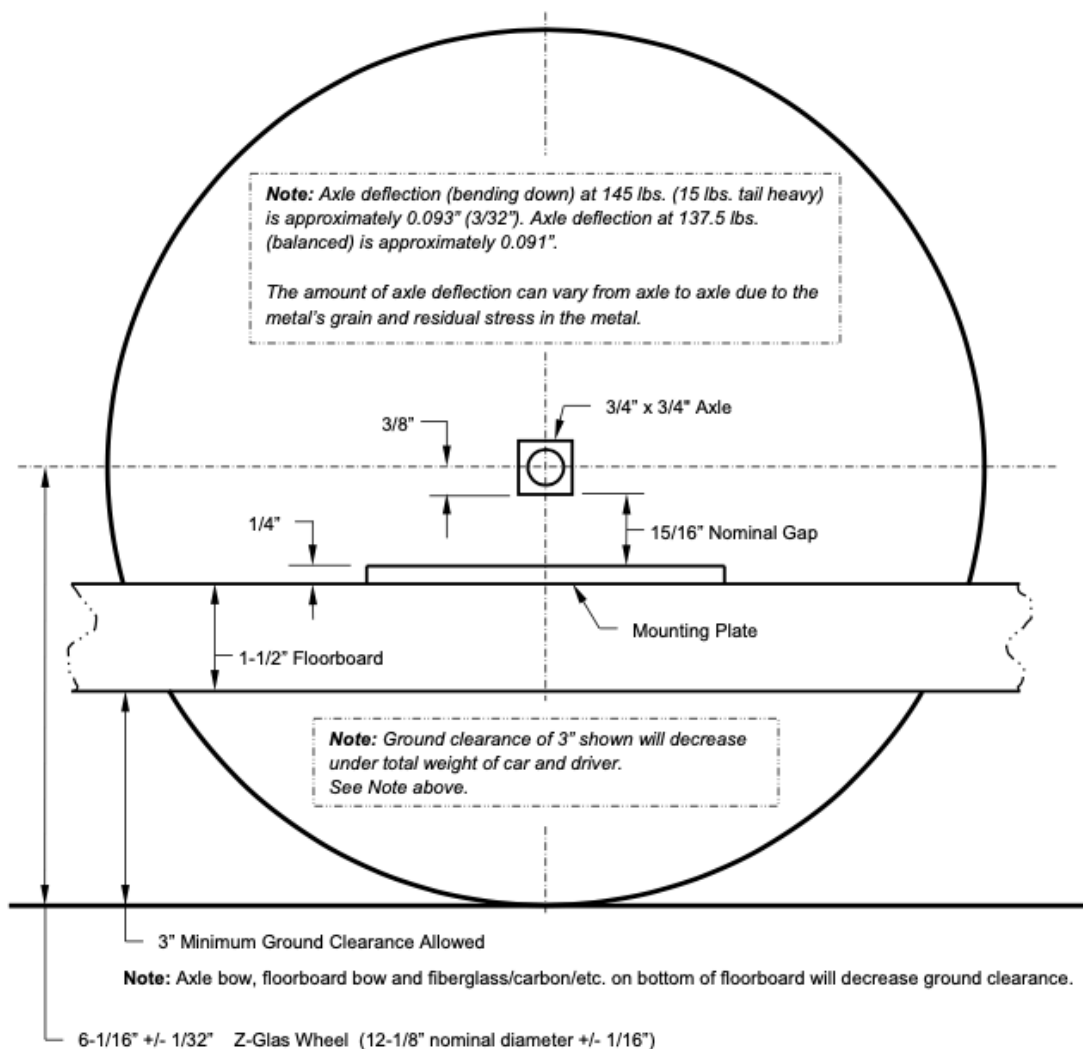

Note: Z-Glas wheels have been found that measure from 12" diameter to 12-1/4" diameter and out-of-round.

Appendix 2: Axle Mount Stack Ups (cont.)

Axle Mount Stack Up – Legacy

The sketch below shows the dimensions for an axle mount stack up using a Z-Glas wheel with a single segment of axle material between the axle and mounting plate.

If a single segment of axle is used between the mounting plate and axle, ground clearance will be 3-3/16" using a nominal diameter Z-Glas wheel. The ground clearance dimension shown in the sketch does not take into account axle bow, floorboard bow, fiberglass/carbon/etc. thickness, or paint thickness added to bottom of floorboard.

A Legacy floorboard sold by Akron can be bowed front to back which will impact ground clearance. During the build process, a floorboard can be intentionally or unintentionally bowed which will impact ground clearance.

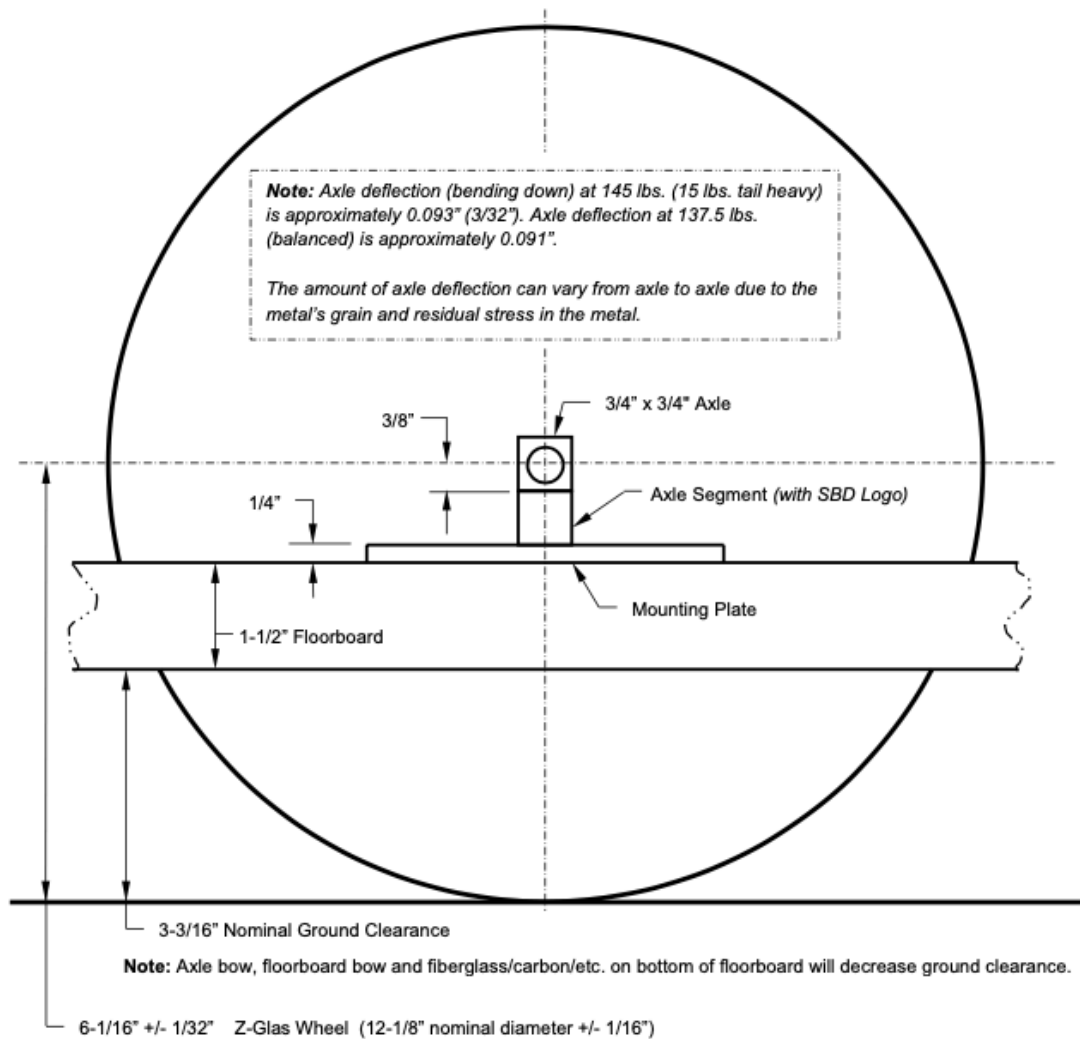

Note: Z-Glas wheels have been found that measure from 12" diameter to 12-1/4" diameter and out-of-round.

Appendix 3: Revision Log

Legacy Car Plans - Revision Log	
Rev New Oct 2018	Updated in Jan 2019 with online FAQs based on inputs from first group of Builders.
Rev A Jan 2020	1) Added new rule requiring cars to run at a minimum weight of 273 lbs, consistent with recent rules changes in the other AASBD divisions.
	2) Added new Figure 3 and clarifying language to Floorboard section, to better explain floorboard thickness requirements
	3) Incorporated guidance from Jan 2019 FAQ around additional inner airfoil mounting axle holes, and associated fillet geometry.
	4) Incorporated guidance from Jan 2019 FAQ allowing use of larger I/D washers and longer or shorter fasteners in Axle Mount section.
	5) Incorporated guidance from Jan 2019 FAQ allowing the covering of fastener heads on the underside of the car with non-transparent fillers.
	6) Incorporated guidance from Jan 2019 FAQ into the Floorboard section clarifying the use of nosecone and tail extensions
	7) Incorporated guidance from Jan 2019 FAQ into Axle Mount section allowing normal flexibility in steel axle mount components and allowing axle material stamps to be covered when assembled, if visible upon disassembly of the mount.
	8) Incorporated other miscellaneous minor clarifications and allowances from Jan 2019 FAQ
	9) Resized, re-oriented, and re-framed certain figures to make them more readable
	10) Added Appendix 1, Summary Table of Key Dimensions and Requirements
	11) Added Appendix 2, Example Axle Mount Stack-ups to assist with designing axle mounts.
	12) Added Appendix 3, Revision Log